

Train path requests for cross-border services

Schaffhausen factsheet

Valid from 10.12.2017



Help document

- For additional information (principles of mandatory entries in NeTS, special rules for cross-border passenger services and examples), please refer to the factsheet help document:

[Passenger services help document](#)

[Freight services help document/example](#)

German sections on CH territory

Overview of national and network borders

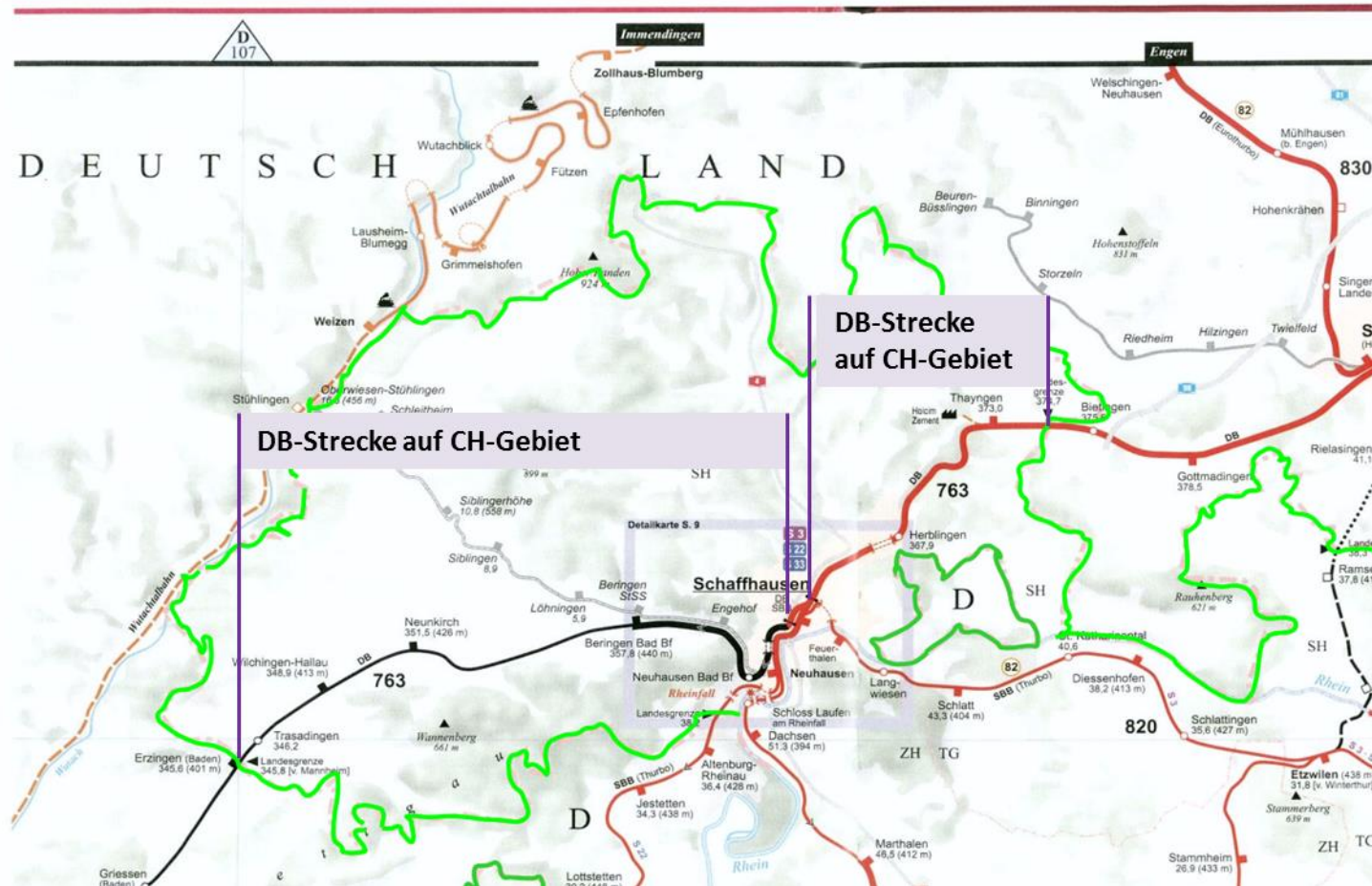

Schaffhausen joint station

Overview of joint borders

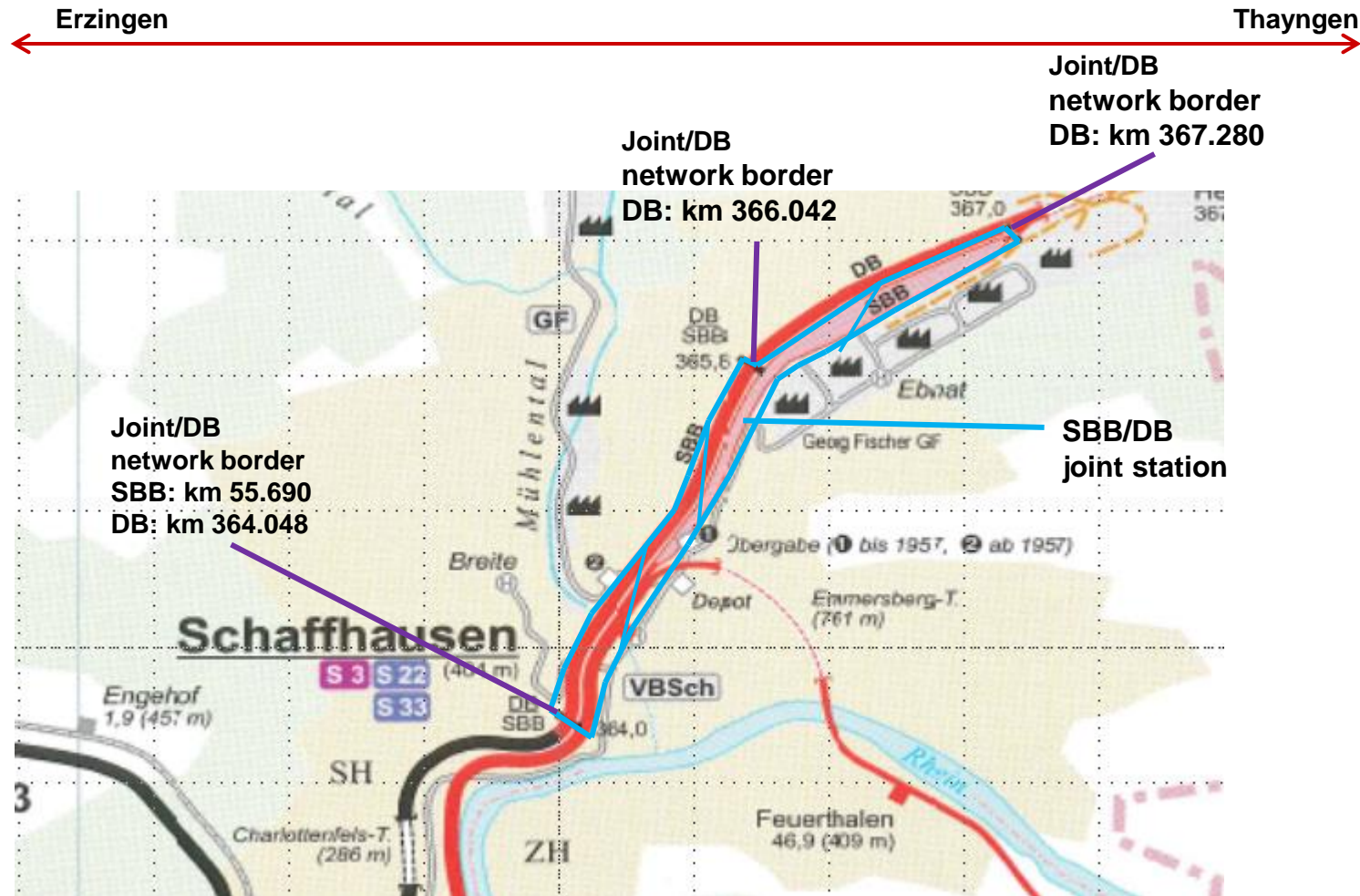

Target status diagram

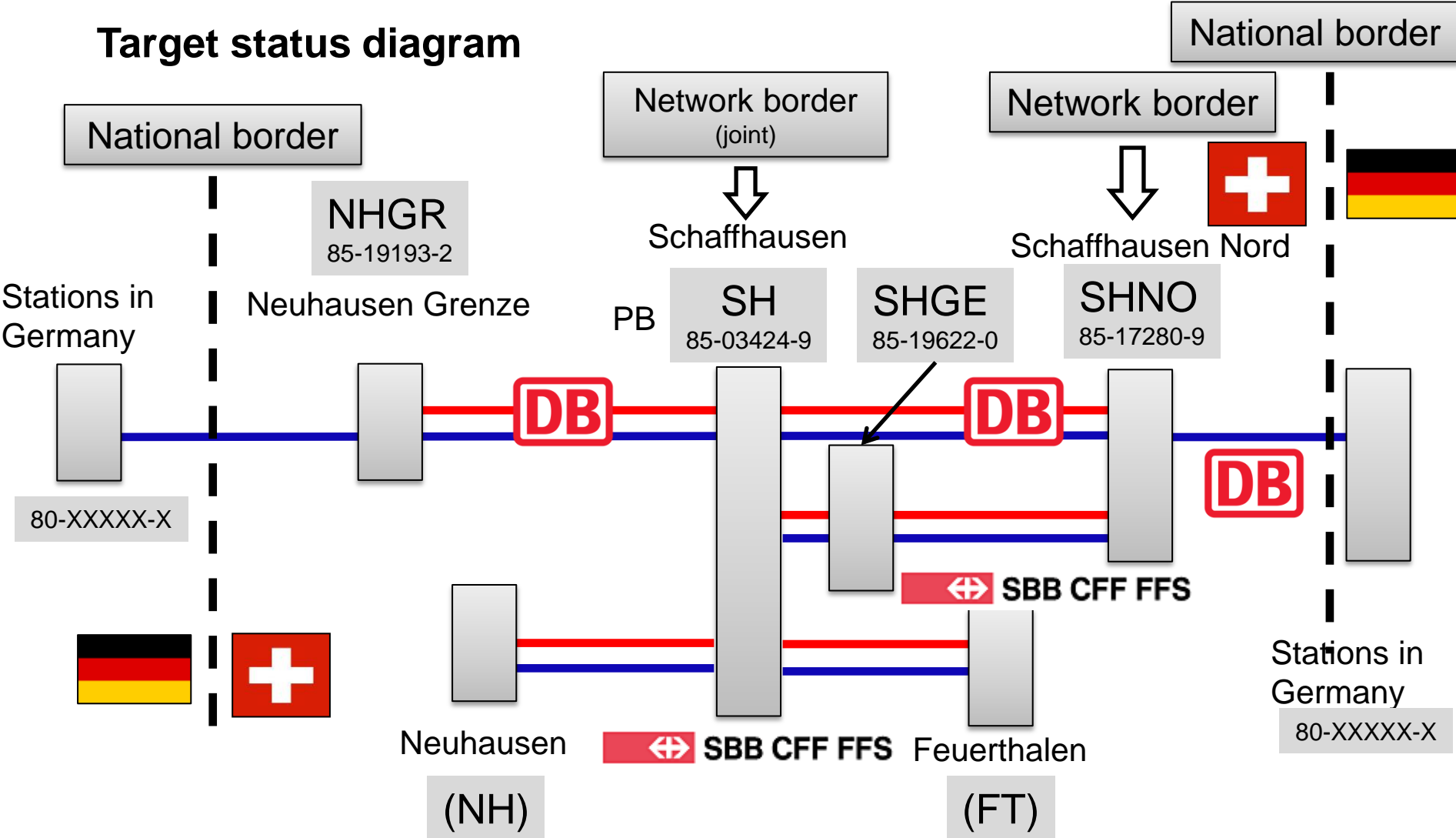

NeTS TED

NeTS ZED

SH and SHGE = handover point/time synchronisation

Operating points to be recorded in AVIS (-NeTS)

To enable all the peripheral systems to function properly at the Schaffhausen border, it is essential that the following operating points are recorded.

Singen → Switzerland Switzerland → Singen				
Operating point	UIC code	Timetable	Purpose of stop	SMS-RU
Stations in Germany	80-XXXXX-X	hh:mm	Code(s)	
Schaffhausen Nord (SHNO)	85-17280-9	hh:mm	32	yes
Schaffhausen PB (SH) Schaffhausen GB (SHGE) ¹⁾	85-03424-9 85-19622-0	hh:mm	yes	yes



¹⁾ If required

Operating points to be recorded in AVIS (-NeTS) (continued)

To enable all the peripheral systems to function properly at the Schaffhausen border, it is essential that the following operating points are recorded.

Waldshut → Switzerland Switzerland → Waldshut				
Operating point	UIC code	Timetable	Purpose of stop	SMS-RU
Stations in Germany	80-XXXXX-X	hh:mm	Code(s)	
Neuhausen Grenze (NHGR)	85-19193-2	hh:mm	32	yes
Schaffhausen PB (SH) Schaffhausen GB (SHGE) ¹⁾	85-03424-9 85-19622-0	hh:mm	yes	yes
Germany – Germany (transit)				
Operating point	UIC code	Timetable	Purpose of stop	SMS-RU
Stations in Germany	80-XXXXX-X	hh:mm	Code(s)	
Neuhausen Grenze (NHGR)	85-19193-2	hh:mm	32	yes
Schaffhausen Nord (SHNO)	85-17280-9	hh:mm	32	yes
Stations in Germany	80-XXXXX-X	hh:mm	Code(s)	

¹⁾ If required